

Issue Date: 07-27-2020
Revised Date: 09-25-2024
Renewal Date: 08-31-2025

DIVISION: 06 00 00 – WOOD, PLASTICS AND COMPOSITES
Section: 06 63 00 – Plastic Railings

REPORT HOLDER:

Shoreline Vinyl Systems
1114 Park Lane
Denton, Maryland 21629
410-364-9050
www.shorelinevinyl.com

ADDITIONAL LISTEES:

TW Perry
8101 Snouffer School Road
Gaithersburg, Maryland 20879
888-897-3779
www.twperry.com

Wolf Home Products
20 West Market Street
York, Pennsylvania 17401
800-388-9353
www.wolfhomeproducts.com

REPORT SUBJECT:

Shoreline PVC Railing Assemblies
100 Series (Traditional Rail)
200 Series (Deckboard Rail)
300 Series (Warrior Rail, Builders Mark Rail)
600 Series (Breadloaf Rail)

1.0 SCOPE OF EVALUATION

1.1 This Research Report addresses compliance with the following Codes:

- 2024, 2021, 2018 *International Building Code*® (IBC)
- 2024, 2021, 2018 *International Residential Code*® (IRC)

NOTE: This report references the most recent Code editions cited. Section numbers in earlier editions may differ.

1.2 The *Shoreline PVC Railing Assemblies* have been evaluated for the following properties:

- Structural Performance
- Durability
- Surface Burning

1.3 The *Shoreline PVC Railing Assemblies* have been evaluated for the following uses:

- The *Shoreline PVC Railing Assemblies* are guards (aka. guardrails) under the definitions of the referenced codes and are intended for use on elevated walking areas in buildings and walkways, including stairs and ramps, as required by the referenced codes.
- Guard assemblies are provided as level guards for level walking areas such as decks, balconies and porches, and sloped guards for open sides of stairways.
- Guard assemblies recognized in this report may be used in One- and Two-Family Dwellings regulated by the IRC and all construction types regulated by the IBC in accordance with IBC Section 705.2. Guards less than 42 inches high are limited to use in One- and Two-Family Dwellings (IRC). See Tables 1 through 4 for additional restrictions based upon Use and Occupancy Classification

2.0 STATEMENT OF COMPLIANCE

The *Shoreline PVC Railing Assemblies* comply with the Codes listed in Section 1.1, for the properties stated in Section 1.2 and uses stated in Section 1.3, when installed as described in this report, including the Conditions of Use stated in Section 6.0.

2.1 2024 IBC and IRC Evaluation Reports

The Intertek CCRR is an *Evaluation Report* for approval of an alternate material, design, or method of construction in



accordance with Section 104.2.3.6.1 of the 2024 IBC and Section R104.2.2.6.1 of the 2024 IRC.

3.0 DESCRIPTION

3.1 The *Shoreline 100 Series (Traditional Rail)* is an assemblage of white co-extruded and molded components, with aluminum reinforcements and nylon mounting brackets. See Figure 1.

3.1.1 Top rails are nominally 3-1/2 inches high by 3-1/2 inches wide with 0.08-inch nominal wall thickness, “T” shaped extruded PVC rail profile, reinforced with an aluminum “H” or “A” insert.

3.1.2 Bottom rails are nominally 2 inches high by 3-1/2 inches wide, extruded PVC rail profile, reinforced with an aluminum “T” insert. The aluminum insert is optional when the railing system is limited to maximum 96- x 36-inch level installations under the IRC. See Table 1.

3.2 The *Shoreline 200 Series (Deckboard Rail)* are an assemblage of white co-extruded and molded components, with aluminum reinforcements and nylon mounting brackets. See Figure 2.

3.2.1 Top rails are nominally 2 inches high by 3-1/2 inches wide, extruded PVC rail profile, reinforced with an aluminum “A” insert.

3.2.2 Bottom rails are nominally 2 inches high by 3-1/2 inches wide, extruded PVC rail profile, reinforced with an aluminum “T” insert.

3.3 The *Shoreline 300 Series (Warrior Rail, Builders Mark Rail)* is an assemblage of white co-extruded and molded components, with aluminum reinforcements and nylon mounting brackets. See Figure 3.

3.3.1 Top rails are nominally 3 inches high by 1-3/4 inches wide with 0.104-inch nominal wall thickness, “T” shaped extruded PVC rail profile, reinforced with an aluminum insert.

3.3.2 Bottom rails for the *300 Series* and *Warrior Rail* are nominally 2-1/4 inches high by 2 inches wide, extruded PVC rail profile, reinforced with an aluminum “H” insert. The *Builders Mark Rail* bottom rails are nominally 3-1/2 inches

high by 2 inches wide, extruded PVC rail profile, reinforced with an aluminum “T” insert.

3.4 The *Shoreline 600 Series (Breadloaf Rail)* is an assemblage of white co-extruded and molded components, with aluminum reinforcements and nylon mounting brackets. See Figure 4.

3.4.1 Top rails are nominally 2-1/4 inches high by 2-13/16 inches wide with 0.08-inch nominal wall thickness, bread loaf shaped extruded PVC rail profile, reinforced with an aluminum insert.

3.4.2 Bottom rails are nominally 2-1/4 inches high by 2 inches wide, extruded PVC rail profile, reinforced with an aluminum “H” insert, or alternatively a nominally 3-1/2 inches high by 2 inches wide, extruded PVC rail profile, reinforced with an aluminum “T” insert.

3.5 Infill for *Shoreline PVC Railing Assemblies* are provided in three styles: square PVC pickets, PVC spindles, and round aluminum pickets. Rails are routed to the shape of the infill profile to receive the infill. See Figure 5.

3.5.1 Square PVC pickets are hollow, extruded PVC, 1-3/8 inch or 1-1/2-inch square, with 0.07-inch nominal wall thickness.

3.5.2 PVC spindles are hollow, thermoformed PVC with 1-1/4 inch or 1-1/2-inch square ends, and 0.06-inch nominal wall thickness.

3.5.3 Round aluminum pickets are hollow, extruded aluminum of 3/4 inch diameter and 0.05-inch nominal wall thickness.

3.6 Top and bottom rails are connected to support posts using nylon brackets, as defined in Table 5. Support posts may be sleeved conventional wood posts, *LMT Galvanized* post mounts or *LMT Blu-Mount* post mounts. The LMT post mounts include PVC post guides (mounting blocks) for securing the rail brackets.

3.6.1 *LMT Galvanized* post mounts consist of a 2-inch square galvanized steel tube with a 0.073-inch-thick wall, continuously fillet welded to a 3-1/2-inch square, 0.300-inch-thick steel base plate. Four 0.40-inch diameter holes





are located at each corner of the plate, with the center of the holes 0.40 inches from each edge.

3.6.2 *LMT Blu-Mount* post mounts consist of a 2-inch square steel tube with 0.152-inch-thick wall, continuously fillet welded to a 3-1/2-inch square, 0.623-inch-thick steel base plate. Four 0.38-inch diameter holes are located at each corner of the plate, with the center of the holes 0.38 inches from each edge.

4.0 PERFORMANCE CHARACTERISTICS

4.1 The *Shoreline PVC Railing Assemblies* described in this report have demonstrated the capacity to resist the design loads specified in Chapter 16 of the IBC, as well as Section R301 of the IRC when tested in accordance with ICC-ES AC174.

4.2 Structural performance has been demonstrated for a temperature range from -20°F to 125°F.

4.3 Materials used are deemed equivalent to preservative treated or naturally durable wood for resistance to weathering effects, decay, and attack from termites.

4.4 Materials used in the railing assemblies have a flame spread index not exceeding 200 when tested in accordance with ASTM E84.

5.0 INSTALLATION

The *Shoreline PVC Railing Assemblies* must be installed in accordance with the manufacturer's published installation instructions, the applicable Code, and this Research Report. A copy of the manufacturer's instructions must be available on the jobsite during installation.

5.1 Railing assemblies consist of top and bottom rails with pre-routed holes to receive infill. Aluminum railing reinforcements are inserted in the rails during assembly as specified for the type and length of railing (see Tables 1 through 4). Aluminum insert lengths must be the same length as the PVC railings to assure bracket screws penetrate the aluminum inserts.

5.2 Railings are secured to sleeved 4x4 wood posts, *LMT Galvanized* post mounts, or *LMT Blu-Mount* post mounts with nylon brackets and stainless-steel screws. The wood in

the supporting structure shall have a specific gravity of 0.55 or greater (Southern Yellow Pine or better) and a minimum thickness to allow full penetration of the bracket mounting screws. Rail attachment shall be in accordance with Table 5.

5.3 The *LMT Galvanized* and *LMT Blu-Mount* post mounts may be surface mounted to concrete utilizing four anchor bolts. The type and length of the anchor bolts is dependent upon the material and condition of the supporting structure and is not within the scope of this report. See Section 6.0, Conditions of Use for additional requirements.

6.0 CONDITIONS OF USE

6.1 Installation must comply with this Research Report, the manufacturer's published installation instructions, and the applicable Code. In the event of a conflict, this report governs.

6.2 See Section 1.3 for construction type(s) and use classifications.

6.3 Conventional wood railing supports, including 4x4 posts and framing, are not within the scope of this report and are subject to evaluation and approval by the building official. Supports must satisfy the design load requirements specified in Chapter 16 of the IBC. Supports and framing must provide suitable material for anchorage of the rail brackets and post mount, respectively. Where required by the building official, engineering calculations and details shall be provided.

6.4 Concrete anchors and anchoring systems for use with the *LMT Galvanized* and *LMT Blu-Mount* post mounts are not within the scope of this report and are subject to evaluation and approval by the building official. Anchors must satisfy the design load requirements specified in Chapter 16 of the building code and must meet the following minimum requirements:

6.4.1 A minimum of four anchor bolts must be used and located in the four pre-drilled holes in the post base plate.

6.4.2 The anchors must be stainless steel, galvanized steel or other approved material compatible with the steel post mount system.

6.4.3 The anchor bolts must have a minimum diameter of 3/8 inches and utilize flat washers. The type and length of





the anchor bolts is dependent upon the material and condition of the supporting structure and is not within the scope of this report.

6.4.4 When the supporting structure is a wood framed deck, installation must include anchorage to suitable structural framing. Decking is not considered structural framing, and anchorage to decking alone is not an approved installation method.

6.4.5 Where required by the building official, engineering calculations and details shall be provided. The calculations shall verify that the anchorage and supporting structure complies with the building code for the type and condition of the supporting construction.

6.5 Any component or configuration not identified in this report has not been evaluated for performance and/or compliance to the referenced codes. Identification of such components with the CCRR program mark or number is prohibited.

6.6 Only those types of fasteners and fastening methods described in this report have been evaluated for the installation of the Shoreline Vinyl Railing Assemblies; other methods of attachment are outside the scope of this report.

6.7 Compatibility of fasteners and other installation hardware with the supporting construction including treated wood is not within the scope of this report.

6.8 The *Shoreline PVC Railing Assemblies* are manufactured under a quality control program with inspections by Intertek Testing Services NA, Inc.

7.0 SUPPORTING EVIDENCE

7.1 Manufacturer's drawings and installation instructions.

7.2 Reports of testing demonstrating compliance with ICC-ES AC174, Acceptance Criteria for Deck Board Span Ratings and Guardrail Systems (Guards and Handrails), revised December 2014.

7.3 Reports of testing and engineering analysis demonstrating compliance with the performance requirements of ASTM D7032-21, Standard Specification for

Establishing Performance Ratings for Wood-Plastic Composite and Plastic Lumber Deck Boards, Stair Treads, Guards, and Handrails.

7.4 Documentation of an Intertek approved quality control system for the manufacturing of products recognized in this report.

7.5 Intertek Listing Report "[Shoreline Vinyl Systems - 100, 200, 300, 600 Series PVC Guardrail Systems](#)", on the [Intertek Directory of Building Products](#).

8.0 IDENTIFICATION

The *Shoreline PVC Railing Assemblies* are identified with the manufacturer's name, address and telephone number, the product name, the statement "See CCRR-0326 for uses and performance levels.", the phrase "For Use in One- and Two-Family Dwellings Only" for the applicable railing assemblies (See Tables 1 through 4), the Intertek Control Number, the Intertek Mark as shown below, and the Code Compliance Research Report number (CCRR-0326).



9.0 OTHER CODES

This section is not applicable.

10.0 CODE COMPLIANCE RESEARCH REPORT USE

10.1 Approval of building products and/or materials can only be granted by a building official having legal authority in the specific jurisdiction where approval is sought.

10.2 Code Compliance Research Reports shall not be used in any manner that implies an endorsement of the product by Intertek.

10.3 Reference to the <https://bpdirectory.intertek.com> is recommended to ascertain the current version and status of this report.





TABLE 1 – 100 SERIES (TRADITIONAL RAIL) PVC RAILING ASSEMBLIES FOR USE GROUP CLASSIFICATIONS

Type	Maximum Railing Dimensions ^{(1) (3)}	Top Rail Aluminum Reinforcement	Support Post ⁽²⁾	Use Group Classification
Level	96 x 42 inches	Aluminum “H” profile with 0.085-inch nominal wall thickness	Conventional 4x4 wood post or <i>LMT Blu-Mount</i> post mount	IBC – All Use Groups IRC – One and Two-Family Dwellings
Stair	94 x 42 inches	Aluminum “H” profile with 0.085-inch nominal wall thickness	Conventional 4x4 wood post or <i>LMT Blu-Mount</i> post mount	
Level	96 x 36 inches ⁽⁴⁾	Aluminum “A” profile with 0.060-inch nominal wall thickness	Conventional 4x4 wood post or <i>LMT Galvanized</i> post mount	IRC – One and Two-Family Dwellings
	120 x 36 inches	Aluminum “H” profile with 0.085-inch nominal wall thickness	Conventional 4x4 wood post or <i>LMT Galvanized</i> post mount	
Stair	117 x 36 inches	Aluminum “A” profile with 0.085-inch nominal wall thickness	Conventional 4x4 wood post or <i>LMT Galvanized</i> post mount	

⁽¹⁾ Level rail lengths are maximum clear length between supports. Railing height is the minimum installed height from walking surface to top of top rail. Stair rail lengths are the sloping clear distance between supports.

⁽²⁾ Anchorage of wood posts and post mounts to the supporting structure is not included in the scope of this report. See Section 6.4 for conditions of use.

⁽³⁾ Bottom rails are 2-inch x 3.5-inch profile reinforced with an aluminum “T” profile with 0.055-inch nominal wall thickness, unless otherwise noted.

⁽⁴⁾ Bottom rail reinforcement is optional for this configuration.

This Code Compliance Research Report (“Report”) is for the exclusive use of Intertek’s Client and is provided pursuant to the agreement between Intertek and its Client. Intertek’s responsibility and liability are limited to the terms and conditions of the agreement. Intertek assumes no liability to any party, other than to the Client in accordance with the agreement, for any loss, expense or damage occasioned by the use of this Report. Only the Client is authorized to permit copying or distribution of this Report and then only in its entirety, and the Client shall not use the Report in a misleading manner. Client further agrees and understands that reliance upon the Report is limited to the representations made therein. The Report is not an endorsement or recommendation for use of the subject and/or product described herein. This Report is not the Intertek Listing Report covering the subject product and utilized for Intertek Certification and this Report does not represent authorization for the use of any Intertek certification marks. Any use of the Intertek name or one of its marks for the sale or advertisement of the tested material, product or service must first be approved in writing by Intertek.



545 E. Algonquin Road • Arlington Heights • Illinois • 60005
intertek.com/building





TABLE 2 – 200 SERIES (DECKBOARD RAIL) PVC RAILING ASSEMBLIES FOR USE GROUP CLASSIFICATIONS

Type	Maximum Railing Dimensions ⁽¹⁾	Top Rail Aluminum Reinforcement	Support Post ⁽²⁾	Use Group Classification
Level	120 x 42 inches	Aluminum "A" profile with 0.085-inch nominal wall thickness	Conventional 4x4 wood post or <i>LMT Blu-Mount</i> post mount	IBC – All Use Groups IRC – One and Two-Family Dwellings
Stair	94 x 42 inches	Aluminum "A" profile with 0.085-inch nominal wall thickness	Conventional 4x4 wood post or <i>LMT Blu-Mount</i> post mount	
Level	96 x 36 inches	Aluminum "A" profile with 0.060-inch nominal wall thickness	Conventional 4x4 wood post or <i>LMT Galvanized</i> post mount	IRC – One and Two-Family Dwellings

⁽¹⁾ Level rail lengths are maximum clear length between supports. Railing height is the minimum installed height from walking surface to top of top rail. Stair rail lengths are the sloping clear distance between supports. Stair heights indicate minimum allowed height as measured vertically from the leading edge of the stair nose.

⁽²⁾ Anchorage of wood posts and post mounts to the supporting structure is not included in the scope of this report. See Section 6.4 for conditions of use.

⁽³⁾ Bottom rails are 2-inch x 3.5-inch profile reinforced with an aluminum "T" profile with 0.055-inch nominal wall thickness.





TABLE 3 – 300 SERIES (WARRIOR RAIL, BUILDERS MARK RAIL) PVC RAILING ASSEMBLIES FOR USE GROUP CLASSIFICATIONS

Type	Maximum Railing Dimensions ⁽¹⁾	Top Rail Aluminum Reinforcement	Support Post ⁽²⁾	Use Group Classification
Level	96 x 42 inches	Aluminum profile with 0.100-inch nominal wall thickness	Conventional 4x4 wood post or <i>LMT Blu-Mount</i> post mount	IBC – All Use Groups IRC – One and Two-Family Dwellings
Stair	89-1/2 x 42 inches	Aluminum profile with 0.100-inch nominal wall thickness		
Level	96 x 42 inches	Aluminum profile with 0.070-inch nominal wall thickness	Conventional 4x4 wood post or <i>LMT Galvanized</i> post mount	IRC – One and Two-Family Dwellings
	120 x 42 inches	Aluminum profile with 0.100-inch nominal wall thickness		
Stair	95-1/2 x 42 inches	Aluminum profile with 0.070-inch nominal wall thickness	Conventional 4x4 wood post or <i>LMT Galvanized</i> post mount	
	119 x 42 inches	Aluminum profile with 0.100-inch nominal wall thickness		

⁽¹⁾ Level rail lengths are maximum clear length between supports. Railing height is the minimum installed height from walking surface to top of top rail. Stair rail lengths are the sloping clear distance between supports. Stair heights indicate minimum allowed height as measured vertically from the leading edge of the stair nose.

⁽²⁾ Anchorage of wood posts and post mounts to the supporting structure is not included in the scope of this report. See Section 6.4 for conditions of use.

⁽³⁾ Bottom rails are one of two options:

- 300 Series and Warrior Rail: 2-inch x 2.25-inch profile reinforced with aluminum “H” profile with 0.055-inch nominal wall thickness
- Builders Mark Rail: 2-inch x 3.5-inch profile reinforced with an aluminum “T” profile with 0.055-inch nominal wall thickness.





TABLE 4 – 600 SERIES (BREADLOAF RAIL) PVC RAILING ASSEMBLIES FOR USE GROUP CLASSIFICATIONS

Type	Maximum Railing Dimensions ⁽¹⁾	Top Rail Aluminum Reinforcement	Support Post ⁽²⁾	Use Group Classification
Level	96 x 42 inches	Aluminum profile with 0.100-inch nominal wall thickness	Conventional 4x4 wood post or <i>LMT Blu-Mount</i> post mount	IBC – All Use Groups IRC – One and Two-Family Dwellings
Stair	94 x 42 inches	Aluminum profile with 0.100-inch nominal wall thickness		
Level	96 x 42 inches	Aluminum profile with 0.070-inch nominal wall thickness	Conventional 4x4 wood post or <i>LMT Galvanized</i> post mount	IRC – One and Two-Family Dwellings
	120 x 42 inches	Aluminum profile with 0.100-inch nominal wall thickness		
Stair	118-1/2 x 42 inches	Aluminum profile with 0.100-inch nominal wall thickness	Conventional 4x4 wood post or <i>LMT Blu-Mount</i> post mount	

⁽¹⁾ Level rail lengths are maximum clear length between supports. Railing height is the minimum installed height from walking surface to top of top rail. Stair rail lengths are the sloping clear distance between supports. Stair heights indicate minimum allowed height as measured vertically from the leading edge of the stair nose.

⁽²⁾ Anchorage of wood posts and post mounts to the supporting structure is not included in the scope of this report. See Section 6.4 for conditions of use.

⁽³⁾ Bottom rails are one of two options:

- 2-inch x 2.25-inch profile reinforced with aluminum “H” profile with 0.055-inch nominal wall thickness
- 2-inch x 3.5-inch profile reinforced with an aluminum “T” profile with 0.055-inch nominal wall thickness.





TABLE 5 – FASTENING SCHEDULE

CONNECTION		FASTENER	QUANTITY	
100 Series	Top Rail Bracket	to Post	#10-10 by 1-1/2 inch (0.121-inch minor diameter), pan-head, zinc-coated, self-drilling screws	4
		to Rail	#10-16 by 1 inch (0.141-inch minor diameter), pan-head, zinc-coated, self-drilling screws	4
	Bottom Rail Bracket	to Post	#10-10 by 1-1/2 inch (0.121-inch minor diameter), pan-head, zinc-coated, self-drilling screws	6
		to Rail	#10-16 by 1 inch (0.141-inch minor diameter), pan-head, zinc-coated, self-drilling screws	4
200 Series	Top / Bottom Rail Bracket	to Post	#10-10 by 1-1/2 inch (0.121-inch minor diameter), pan-head, zinc-coated, self-drilling screws	6
		to Rail	#10-16 by 1 inch (0.141-inch minor diameter), pan-head, zinc-coated, self-drilling screws	4
300 Series 600 Series	Top Rail Bracket	to Wood Post	#10-10 by 1-1/2 inch (0.118-inch minor diameter), pan-head, zinc-coated, self-drilling screws	3
		to LMT Post	#10-16 by 1 inch (0.140-inch minor diameter), pan-head, zinc-coated, self-starting screws	3
	300 Series, 600 Series, and Warrior Rail: 2" x 2-1/4" Bottom Rail Bracket	to Wood Post	#10-10 by 1-1/2 inch (0.118-inch minor diameter), pan-head, zinc-coated, self-drilling screws	3
		to LMT Post	#10-16 by 1 inch (0.140-inch minor diameter), pan-head, zinc-coated, self-starting screws	3
		to Rail	#10-16 by 1 inch (0.140-inch minor diameter), pan-head, zinc-coated, self-starting screws	2
	600 Series and Builders Mark Rail: 2" x 3-1/2" Bottom Rail Bracket	to Post	#10-10 by 1-1/2 inch (0.121-inch minor diameter), pan-head, zinc-coated, self-drilling screws	6
to Rail		#10-16 by 1 inch (0.141-inch minor diameter), pan-head, zinc-coated, self-drilling screws	4	
100 Series 200 Series 300 Series 600 Series	Baluster to Top/Bottom Rail		Slip fit into routing - No mechanical connection	-
	Support Block to Bottom Rail		Slip fit into routing - No mechanical connection	-
	Post Mount to Top Stabilizer (internal component)		#10-16 by 1 inch (0.140-inch minor diameter), pan-head, zinc-coated, self-starting screw	1
	Top Stabilizer (internal component) to Top Stabilizer		1/4-20 by 1-1/4-inch hex head stainless steel bolt with nut, plate washer and lock washer	1
	Bottom PVC Post Stabilizer to Post Mount		#10-16 by 1 inch (0.140-inch minor diameter), pan-head, zinc-coated, self-starting screws	1



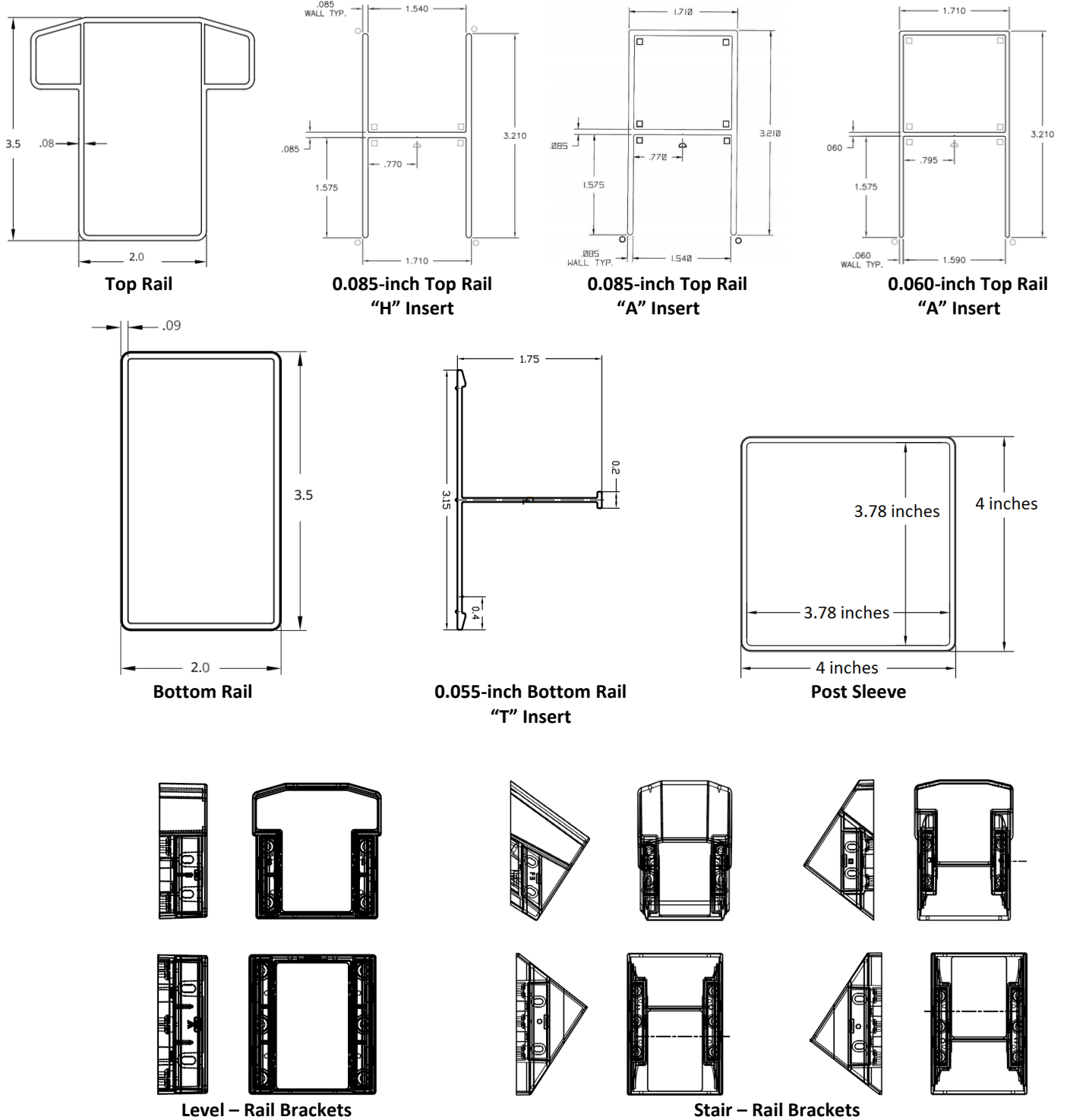

FIGURE 1 – 100 SERIES PVC RAILING PROFILES AND BRACKETS



545 E. Algonquin Road • Arlington Heights • Illinois • 60005
intertek.com/building



PCA-101

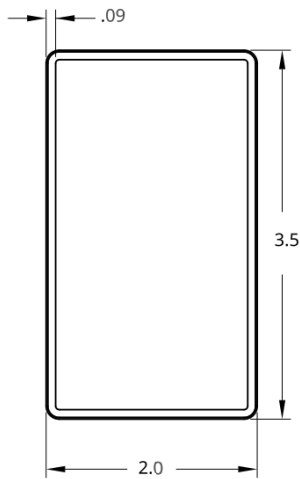

Top Rail

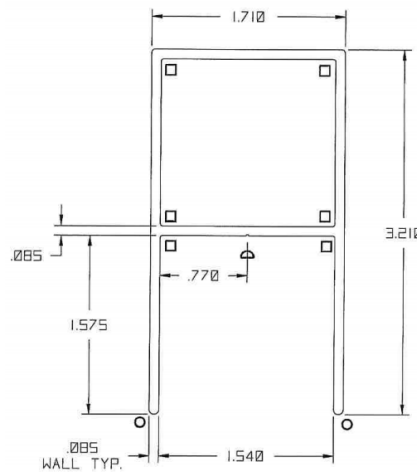

0.085-inch Top Rail "A" Insert

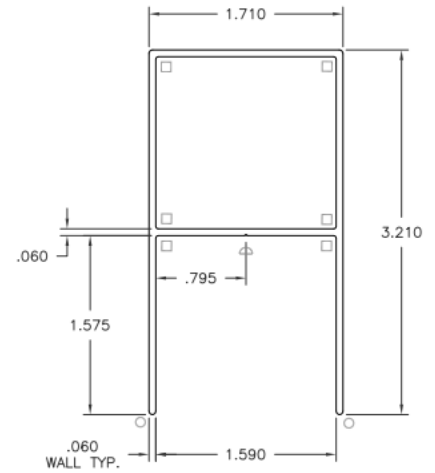

0.060-inch Top Rail "A" Insert

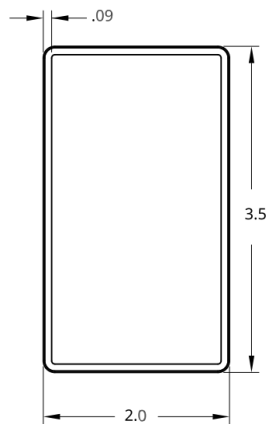

Bottom Rail

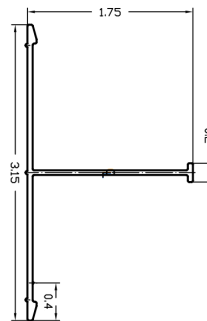

0.055-inch Bottom Rail "T" Insert

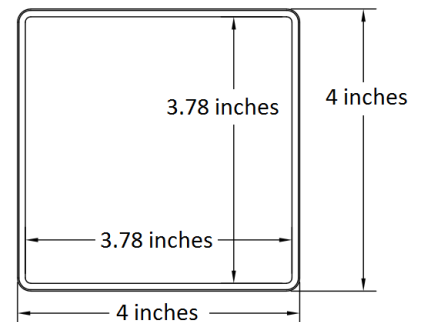

Post Sleeve

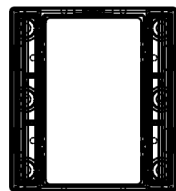
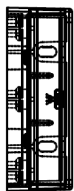

Level – Rail Bracket

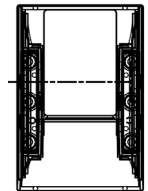
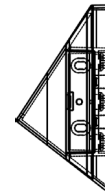
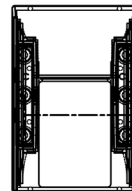
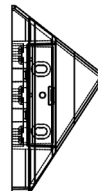

Stair – Rail Brackets

FIGURE 2 – 200 SERIES PVC RAILING PROFILES AND BRACKETS

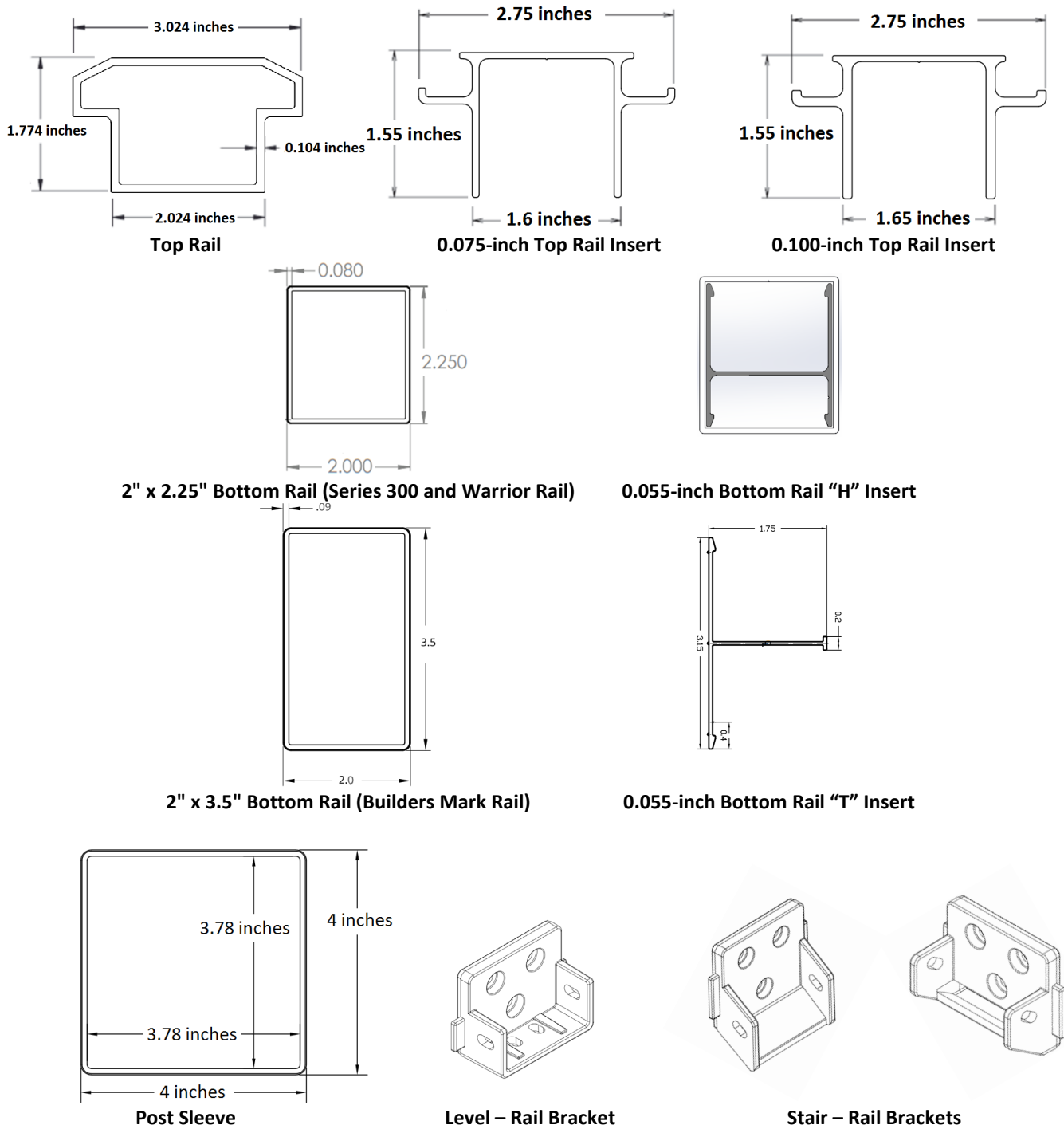

FIGURE 3 – 300 SERIES PVC RAILING PROFILES AND BRACKETS

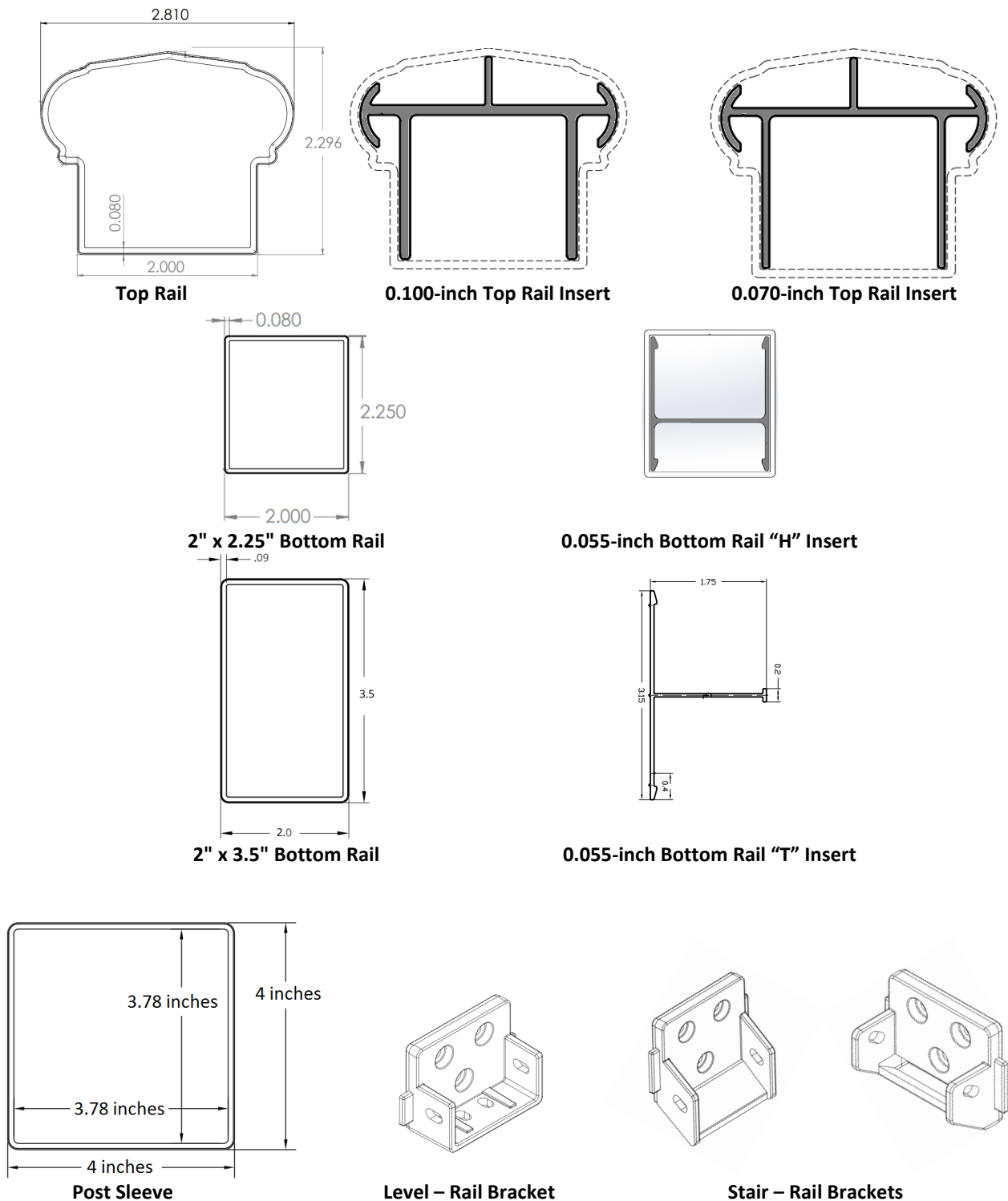
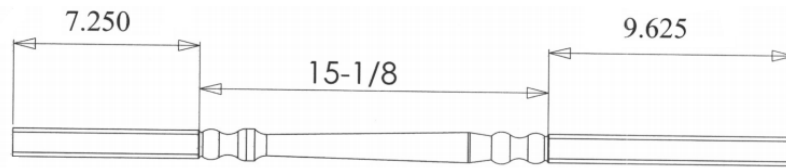
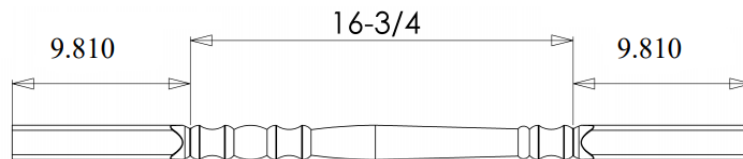

FIGURE 4 – 600 SERIES PVC RAILING PROFILES AND BRACKETS



**1-1/4-inch PVC Spindle
(300, 600 Series Only)**



**1-1/2-inch PVC Spindle
(100, 200 Series Only)**

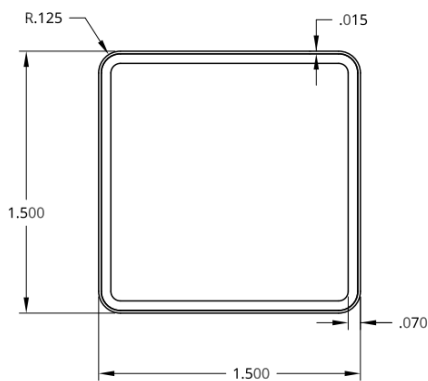

**1-1/2-inch Square PVC Picket
(100, 200 Series Only)**

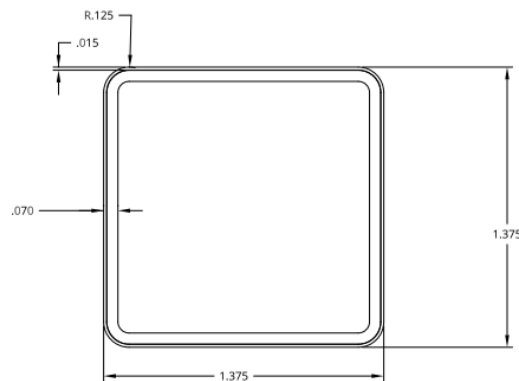

**1-3/8-inch Square PVC Picket
(300, 600 Series Only)**

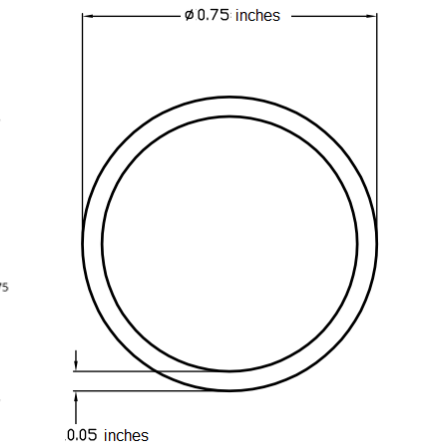

3/4-inch Diameter Aluminum Picket

FIGURE 5 – INFILL



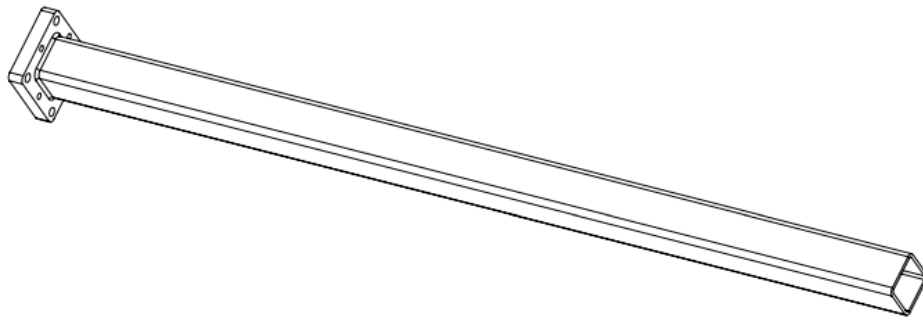

LMT Blu Mount

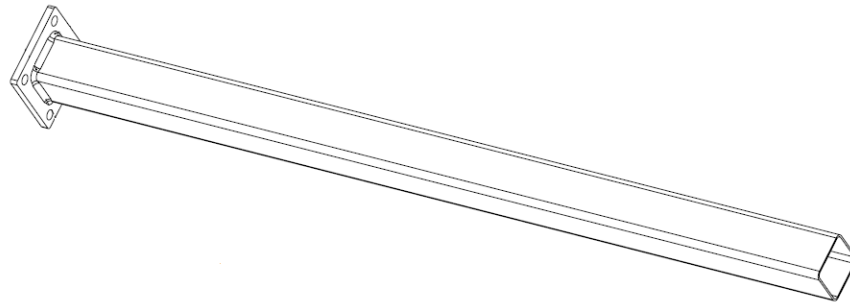

LMT Galvanized

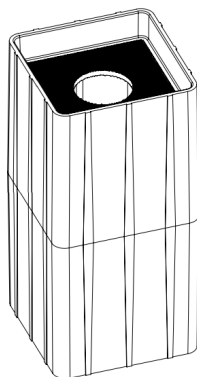

Orientation for 36"

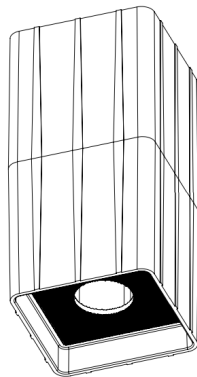

Orientation for 42"

Top Rail Post Guide

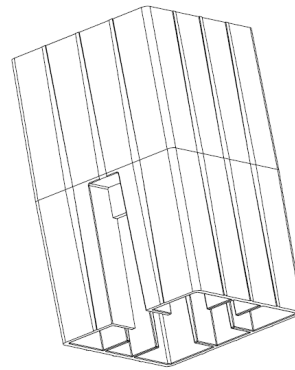

Bottom Rail Post Guide

FIGURE 6 – POST MOUNTS